

N° 4 Fori per nostra produzione
N° 4 Holes for our production

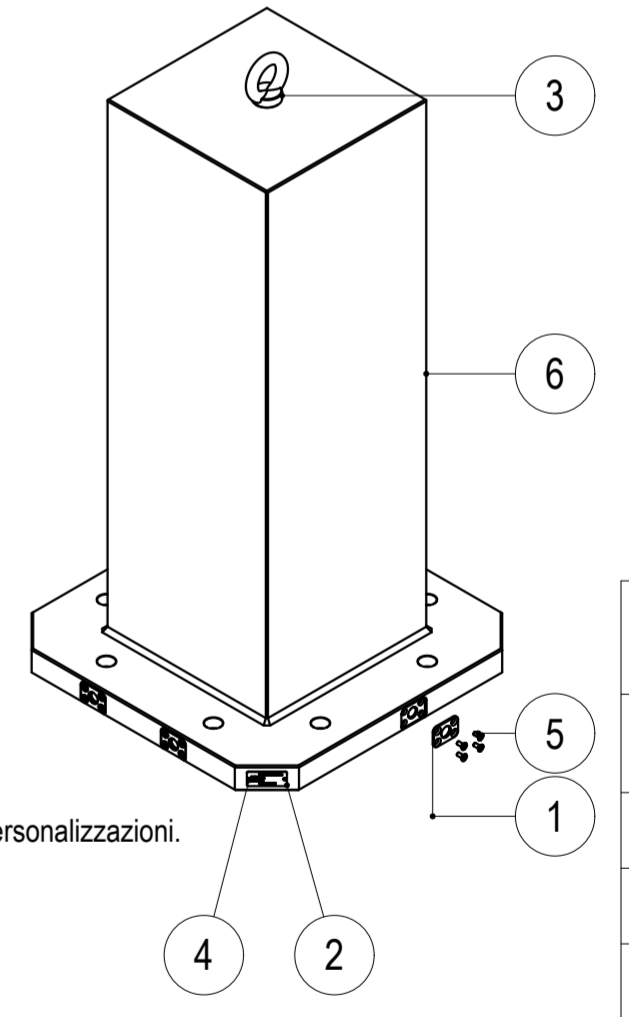

DOTAZIONE STANDARD
-N° 1 Golfare M20

STANDARD EQUIPMENT
-N° 1 M20 Eyebolt

ATTENZIONE:
- quote indicative da verificare in caso di offerta;
- possibile presenza di lavorazioni aggiuntive e/o forature extra;
- verificare la compatibilità della base col proprio pallet;
- possibilità di richiedere un preventivo per eventuali modifiche o personalizzazioni.

ATTENTION:
- indicative dimensions to be verified in the event of an offer;
- possible presence of additional machining and/or extra drilling;
- check the compatibility of the base with your pallet;
- possibility to request a quote for any change or customization.

Rev.	Description	Drawn by	Date	Approved by
A		A.Vigliotta		

SEZIONE B-B
SCALA 1:4

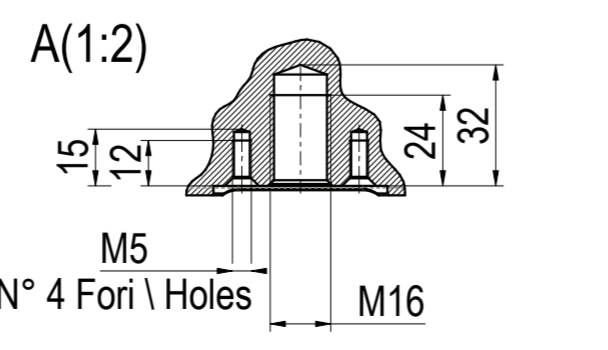
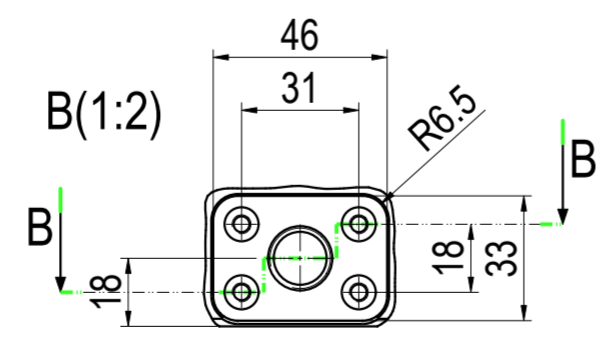
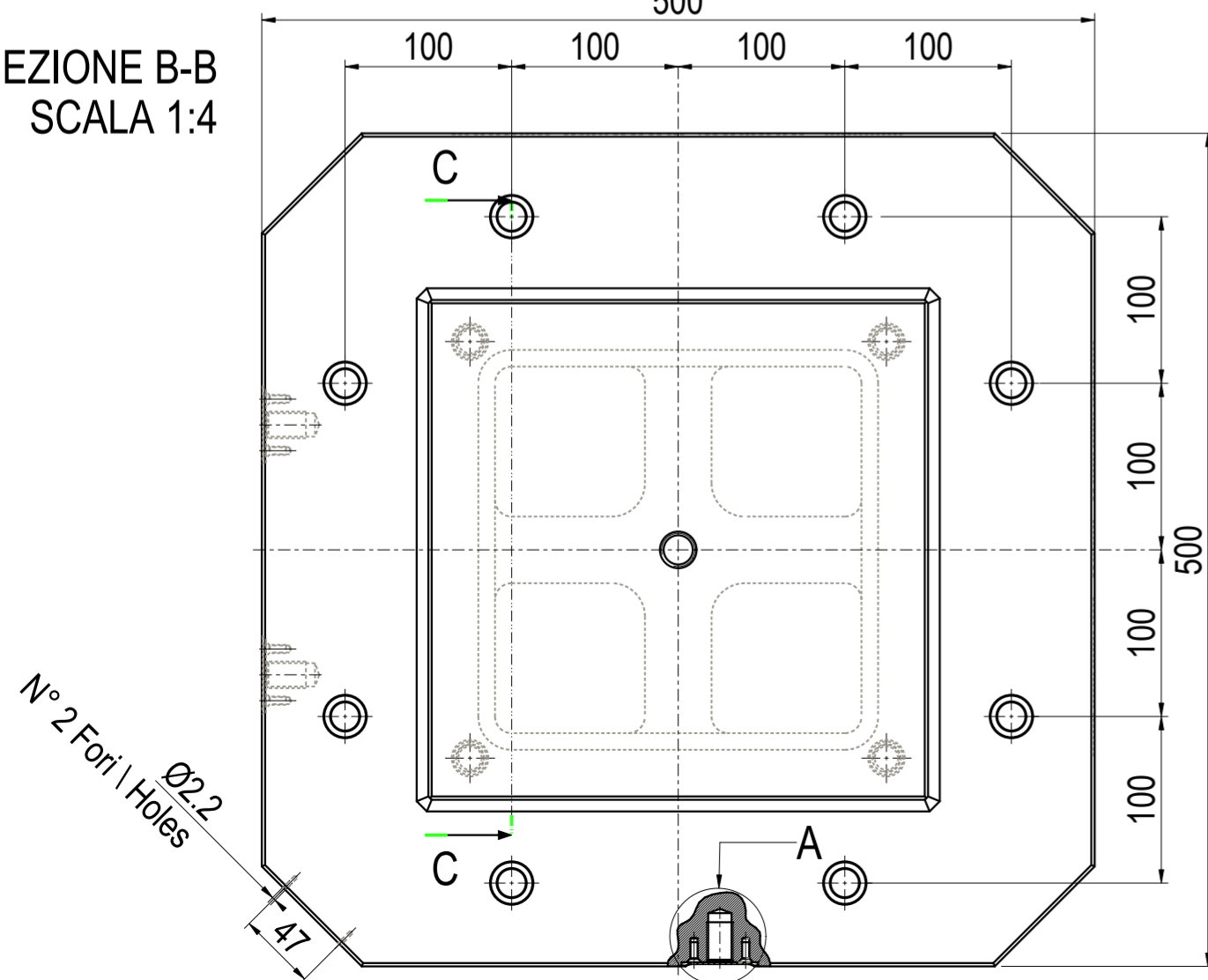

PO S.	CODICE - CODE	DESCRIZIONE - DESCRIPTION	Q. TY
1	4SH45322	Piastrina riferimento laterale Lateral reference plate	3
2	4SH53231	Piastra identificativa Portapezzi Tombstone Serial Number plate	1
3	GOLFARE_M20	Golfare M20 Eyebolt M20	1
4	RIVETTO_2-3X5	Rivetto Ø2.3 x 5 Rivet Ø2.3 x 5	2
5	VTPSEL_M5X12	Vite testa piana svasata esagono incassato Countersunk socket head screw	12
6	W0000522279	Corpo cubo completamente lavorato Completely machined body cube	1

	GERARDI S.p.A. Lonate Pozzolo (VA) Italy Tel. +39 0331303911 Fax +39 0331301534	Denominazione Denomination Progettazione - UTILIZZO ESCLUSIVO UFFICIO TECNICO			
		Articolo Article 53F		Toll. non quotate Tol. not quoted ±0.100	
Materiale Material G30	Tratt. termico Heat treatment Ricottura di distensione / Stress relieving	Tipo Type 115	Spigoli arr. Chamfers 0.500	Fabbisogno Q.ty needed -	Disegnato da Drawn by G. Algeri
Durezza Hardness -	Tratt. superficiale Surface treatment Verniciatura a polvere / Powder coating	Peso Weight Kg 336.20	Foglio Sheet 1 of 1	Approvato da Approved by -	Codice commerciale Sales item code 853C00115
Data Date 06/12/21		Disegno N° Drawing N° W0000522267		Approved by -	